

Sure Cross® Gateway B2T Board Module for a Wireless Q45 Temperature/Humidity Sensor



Datasheet



Sure Cross® embeddable board radio modules provide connectivity where traditional wired connections are not possible or are cost prohibitive. Wireless networks are formed around a Gateway, which acts as the wireless network master device, and one or more Nodes. Sure Cross embeddable board radio modules communicate with all Sure Cross radios.

- Wireless industrial I/O device with two PNP discrete inputs and two analog outputs
- 10 V DC to 30 V DC power input
- Two PNP inputs are mapped directly to the Wireless Q45 Sensor Node's red/green alarm indicator LED
- DIP switches allow the user to select from three scaled temperature ranges for the analog outputs
- Site Survey analyzes the network's signal strength and reliability and conveys the results using the two-color LED
- Frequency Hopping Spread Spectrum (FHSS) technology ensures reliable data delivery
- Transceivers provide bidirectional communication between the Gateway and Node, including fully acknowledged data transmission
- Lost RF links are detected and relevant outputs set to user-defined conditions

For additional information, updated documentation, and a list of accessories, refer to Banner Engineering's website, www.bannerengineering.com.

Models

Models	Frequency	Inputs and Outputs
DX80G2M6-B2T	2.4 GHz ISM Band	Inputs: Two PNP discrete Outputs: Two analog (4 to 20 mA)

Configure and Install Your Q45 Network

Follow these steps to set up and install your Wireless Q45 network.

1. On the Wireless Q45 Sensor Node:
 - a) Configure the DIP switches (if applicable).
 - b) Apply power.
2. On the Gateway or DXM:
 - a) Configure the DIP switches (if applicable).
 - b) Wire the I/O.
 - c) Apply power.
3. Bind the Q45 to the master radio.
4. Observe the LED behavior to verify the devices are communicating to each other.
5. Using the configuration software, configure the I/O mapping between the Q45 and its master radio.
6. Conduct a Site Survey between the Gateway and the Wireless Q45.
7. Install your devices.

Configure the DIP Switches

Before changing DIP switch positions, disconnect the power. Any changes made to the DIP switches are not recognized until after power is cycled to the device.

For devices powered by batteries integrated into the housing, triple-click button 2, then double-click button 2 to reset the device without removing the battery.

For parameters not set using the DIP switches, use the configuration software to make configuration changes. For parameters set using the DIP switches, the DIP switch positions override any changes made using the configuration software.



DIP Switch Settings

Transmit Power

The transmit power for 2.4 GHz is fixed at 100 mW EIRP (18 dBm), making the 2.4 GHz Performance models automatically compatible with the DX80 2.4 GHz models.

Modbus/UCT Configured or DIP Switch Configured

In Modbus/Software Configured mode, use the DX80 Performance Configuration Software or a Modbus command to change the device parameters. DIP switch positions 3 through 8 are ignored. In DIP Switch Configured mode, use the DIP switches to configure the parameters listed in the table. By default, this Gateway uses the DIP switches to configure the device.

DIP Switch	
2	Modbus/UCT Configured or DIP Switch Configured
OFF *	DIP switch configured
ON	Modbus or UCT configured (DIP switches 3–8 are ignored)

I/O Mapping for one Wireless Q45 Temperature/Humidity Sensor to a DX80G2M6-B2T Gateway

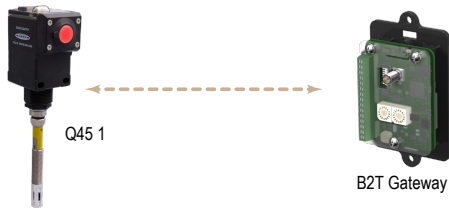

DIP Switches	
5	I/O Mapping
OFF *	Gateway's discrete inputs mapped to the Wireless Q45 Sensor's light outputs Gateway's Discrete IN 1 → Q45's Discrete OUT 1 (red light) Gateway's Discrete IN 2 → Q45's Discrete OUT 2 (green light)
ON	No mapping to the Wireless Q45's light outputs

DIP Switches		
6	7	Temperature Ranges
OFF *	OFF *	Wireless Q45's -40 °C to 85 °C temperature reading to the Gateway's 4 to 20 mA output Q45's Temperature °C → Gateway's Analog OUT 1 Q45's Relative Humidity → Gateway's Analog OUT 2
OFF	ON	Wireless Q45's 0 °C to 85 °C temperature reading to the Gateway's 4 to 20 mA output Q45's Temperature °C → Gateway's Analog OUT 1 Q45's Relative Humidity → Gateway's Analog OUT 2
ON	OFF	Wireless Q45's -20 °C to 60 °C temperature reading to the Gateway's 4 to 20 mA output Q45's Temperature °C → Gateway's Analog OUT 1 Q45's Relative Humidity → Gateway's Analog OUT 2
ON	ON	Custom setting

DIP switches 3, 4, and 8 are not used at this time.

Wire the Gateway's I/O and Apply Power

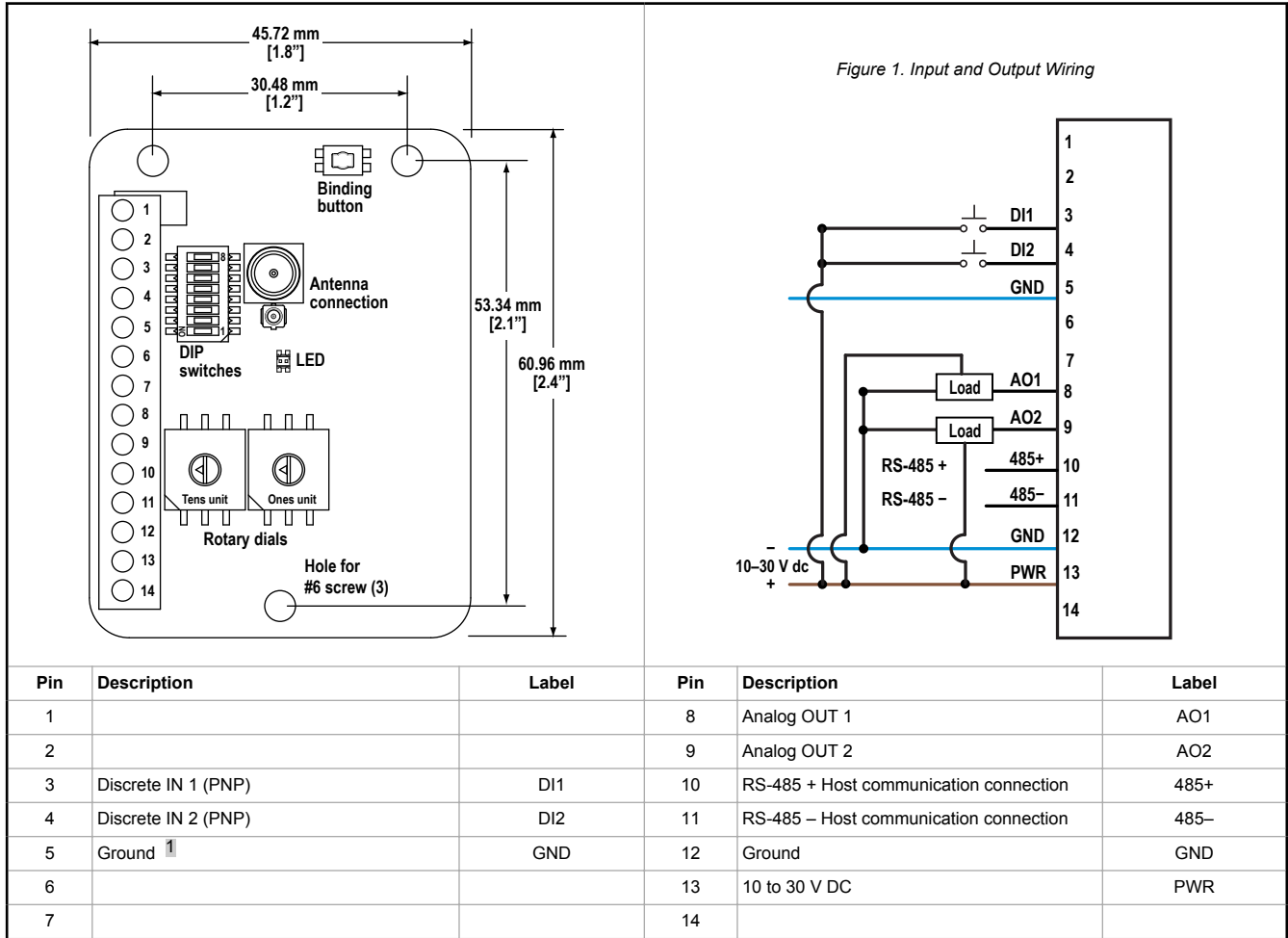

Bind the Wireless Temperature/Humidity Q45 to the B2T Gateway and Assign the Node Address

Before beginning the binding procedure, apply power to all the devices.

1. Enter binding mode on the Gateway by triple-clicking the button. The green and red LED flashes.
2. Assign the Q45 a Node address or 01 using the Gateway's rotary dials. Set the left dial to 0 and the right dial to 1.
3. Loosen the clamp plate on the top of the Wireless Q45 and lift the cover.
4. Enter binding mode on the Wireless Q45 by triple-clicking the button. The red and green LEDs flash alternately and the sensor searches for a Gateway in binding mode. After the Q45 is bound, the LEDs stay solid momentarily, then they flash together four times. The Q45 exits binding mode.
5. After binding the Wireless Temperature/Humidity Q45, exit binding mode on the Gateway by double-clicking the button.

LED Behavior for the Gateways

Verify all devices are communicating properly. The radios and antennas must be a minimum distance apart to function properly. Recommended minimum distances are:

- 900 MHz 150 mW and 250 mW radios: 6 feet
- 900 MHz 1 Watt radios: 15 feet
- 2.4 GHz 65 mW radios: 1 foot

LED (Bi-color)	Gateway Status
Solid green	Power ON
Green and red flashing alternately	Binding mode

¹ The three ground connections are tied together internally.

LED (Bi-color)	Gateway Status
Flashing red	Device Error
Green and red flashing together, looks amber	Modbus Communication Active
Flashing red	Modbus Communication Error
Solid red	Gateway is trying to conduct a Site Survey with a Node that doesn't exist
Green and red solid together, looks amber)	No radio communication detected

For Gateway and Ethernet Bridge systems, active Modbus communication refers to the communication between the Gateway and the Ethernet Bridge. For Gateway-only systems, the Modbus communication LEDs refer to the communication between the Gateway and its host system (if applicable).

Conduct a Site Survey from a Gateway Board Model

Conducting a Site Survey, also known as an RSSI (Radio Signal Strength Indication), analyzes the radio communications link between the Gateway and any Node within the network by analyzing the radio signal strength of received data packets and reporting the number of missed packets that required a retry.

Perform a Site Survey before permanently installing the radio network to ensure reliable communication. Only the Gateway can initiate a Site Survey, and the Site Survey analyzes the radio communications link with one Node at a time. Follow these steps to conduct a Site Survey from the board module Gateway.

- Set the Gateway's rotary dials to the Node address you'd like to conduct a Site Survey with.
 For example, to analyze the signal strength between this Gateway and Node 02, rotate the left rotary dial to 0 and the right rotary dial to 2.
 The Site Survey automatically begins running. If there is no device at address 02, the LED is solid red. If there is a device at address 02, the LED flashes amber.
- Evaluate the signal strength. The amber LED flashes at specific rates to indicate the Site Survey results. Each signal strength represents the majority of the data packets being received at that signal strength. For example, a strong signal strength indicates the majority of the data packets were received at a strong signal, but a few may have been received at a good or weak signal strength.
 - Eight flashes per second: Very strong signal strength
 - Four flashes per second: Strong signal strength
 - Two flashes per second: Good signal strength
 - One flash per second: Weak signal strength
 - Solid amber LED: No radio communication detected
- To exit the Site Survey, set the Gateway's rotary dials to 00. Otherwise, after 15 minutes the Gateway automatically exits Site Survey mode.
 The LED flashes green to indicate the Gateway is in standard operating mode.

Modbus Register Table

I/O #	Modbus Holding Register		I/O Type	I/O Range		Holding Register Representation	
	Gateway	Any Node		Min.	Max.	Min. (Dec.)	Max. (Dec.)
1	1	1 + (Node# × 16)	Discrete IN 1	0	1	0	1
2	2	2 + (Node# × 16)	Discrete IN 2	0	1	0	1
		...					
7	7	7 + (Node# × 16)	Reserved				
8	8	8 + (Node# × 16)	Device Message				
		...					
11	11	11 + (Node# × 16)	Analog OUT 1	4 mA	20 mA	0	65535
12	12	12 + (Node# × 16)	Analog OUT 2	4 mA	20 mA	0	65535
		...					
15	15	15 + (Node# × 16)	Control Message				
16	16	16 + (Node# × 16)	Reserved				

Specifications

Performance 2.4 GHz Radio Specifications

Radio Range²

2.4 GHz, 65 mW: Up to 3.2 km (2 miles)

Antenna Minimum Separation Distance

2.4 GHz, 65 mW: 0.3 m (1 ft)

Radio Transmit Power

2.4 GHz, 65 mW: 18 dBm (65 mW) conducted, less than or equal to 20 dBm (100 mW) EIRP

Spread Spectrum Technology

FHSS (Frequency Hopping Spread Spectrum)

2.4 GHz Compliance

FCC ID UE300DX80-2400: FCC Part 15, Subpart C, 15.247

Radio Equipment Directive (RED) 2014/53/EU

IC: 7044A-DX8024

ANATEL: 15966-21-04042 Este equipamento não tem direito à proteção contra interferência prejudicial e não pode causar interferência em sistemas devidamente autorizados. Para maiores informações, consulte o site da ANATEL www.gov.br/anatel/pt-br/

Antenna Connection

Ext. Reverse Polarity SMA, 50 Ohms

Max Tightening Torque: 0.45 N·m (4 lbf·in)

Link Timeout (Performance)

Gateway: Configurable via User Configuration Software

Node: Defined by Gateway

Specifications for the B2T Gateway

Supply Voltage

10 V DC to 30 V DC; Outside the USA: 12 V DC to 24 V DC, ± 10% (For European applications, power this device from a Limited Power Source as defined in EN 60950-1.)

Interface

One bi-color LED indicator; One button

Discrete Inputs

Rating: 3 mA max current at 30 V DC

Sample Rate: 62.5 milliseconds

Report Rate: On change of state

ON Condition: Greater than 8 V

OFF Condition: Less than 5 V

Analog Output

Update rate: 125 milliseconds

Accuracy: 0.1% of full scale +0.01% per °C

Resolution: 12-bit

Wiring Access

Terminal block

Radiated Immunity

10 V/m (EN 61000-4-3)

Operating Conditions

-40 °C to +85 °C (-40 °F to +185 °F)³

95% maximum relative humidity (non-condensing)

Certifications

Banner Engineering
Europe Park Lane,
Culliganlaan 2F bus 3, 1831
Diegem, BELGIUM

(CE approval only
applies to 2.4 GHz
models)

Accessories for the Board Models

BWA-HW-034

- DIN rail clip, black plastic



² Radio range is with the 2 dB antenna that ships with the product. High-gain antennas are available, but the range depends on the environment and line of sight. Always verify your wireless network's range by performing a Site Survey.

³ Operating the devices at the maximum operating conditions for extended periods can shorten the life of the device.

MultiHop M-HBx and Performance PBx Models Mounted on the Base

Figure 2. Most MultiHop M-HBx and Performance PBx models ship from the factory mounted on a plastic base.

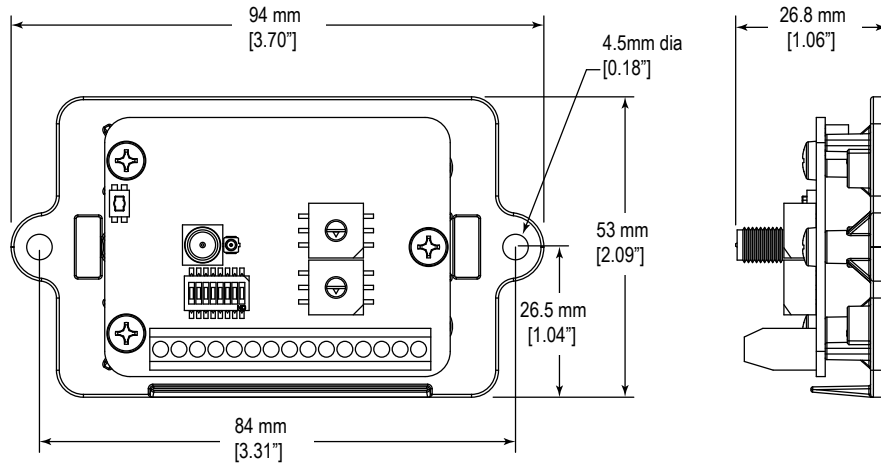

Warnings

Install and properly ground a qualified surge suppressor when installing a remote antenna system. Remote antenna configurations installed without surge suppressors invalidate the manufacturer's warranty. Keep the ground wire as short as possible and make all ground connections to a single-point ground system to ensure no ground loops are created. No surge suppressor can absorb all lightning strikes; do not touch the Sure Cross® device or any equipment connected to the Sure Cross device during a thunderstorm.

Exporting Sure Cross® Radios. It is our intent to fully comply with all national and regional regulations regarding radio frequency emissions. **Customers who want to re-export this product to a country other than that to which it was sold must ensure the device is approved in the destination country.** The Sure Cross wireless products were certified for use in these countries using the antenna that ships with the product. When using other antennas, verify you are not exceeding the transmit power levels allowed by local governing agencies. This device has been designed to operate with the antennas listed on Banner Engineering's website and having a maximum gain of 9 dBm. Antennas not included in this list or having a gain greater than 9 dBm are strictly prohibited for use with this device. The required antenna impedance is 50 ohms. To reduce potential radio interference to other users, the antenna type and its gain should be so chosen such that the equivalent isotropically radiated power (EIRP) is not more than that permitted for successful communication. Consult with Banner Engineering Corp. if the destination country is not on this list.



Important: Please download the complete Performance Gateway or Node technical documentation, available in multiple languages, from www.bannerengineering.com for details on the proper use, applications, Warnings, and installation instructions of this device.



Important: Por favor descargue desde www.bannerengineering.com toda la documentación técnica de los Performance Gateway or Node, disponibles en múltiples idiomas, para detalles del uso adecuado, aplicaciones, advertencias, y las instrucciones de instalación de estos dispositivos.



Important: Veuillez télécharger la documentation technique complète des Performance Gateway or Node sur notre site www.bannerengineering.com pour les détails sur leur utilisation correcte, les applications, les notes de sécurité et les instructions de montage.

**WARNING:**

- **Do not use this device for personnel protection**
- Using this device for personnel protection could result in serious injury or death.
- This device does not include the self-checking redundant circuitry necessary to allow its use in personnel safety applications. A device failure or malfunction can cause either an energized (on) or de-energized (off) output condition.

**Important:**

- **Never operate a 1 Watt radio without connecting an antenna**
- Operating 1 Watt radios without an antenna connected will damage the radio circuitry.
- To avoid damaging the radio circuitry, never apply power to a Sure Cross® Performance or Sure Cross MultiHop (1 Watt) radio without an antenna connected.



Important:

- **Electrostatic discharge (ESD) sensitive device**
- ESD can damage the device. Damage from inappropriate handling is not covered by warranty.
- Use proper handling procedures to prevent ESD damage. Proper handling procedures include leaving devices in their anti-static packaging until ready for use; wearing anti-static wrist straps; and assembling units on a grounded, static-dissipative surface.

Banner Engineering Corp. Limited Warranty

Banner Engineering Corp. warrants its products to be free from defects in material and workmanship for one year following the date of shipment. Banner Engineering Corp. will repair or replace, free of charge, any product of its manufacture which, at the time it is returned to the factory, is found to have been defective during the warranty period. This warranty does not cover damage or liability for misuse, abuse, or the improper application or installation of the Banner product.

THIS LIMITED WARRANTY IS EXCLUSIVE AND IN LIEU OF ALL OTHER WARRANTIES WHETHER EXPRESS OR IMPLIED (INCLUDING, WITHOUT LIMITATION, ANY WARRANTY OF MERCHANTABILITY OR FITNESS FOR A PARTICULAR PURPOSE), AND WHETHER ARISING UNDER COURSE OF PERFORMANCE, COURSE OF DEALING OR TRADE USAGE.

This Warranty is exclusive and limited to repair or, at the discretion of Banner Engineering Corp., replacement. **IN NO EVENT SHALL BANNER ENGINEERING CORP. BE LIABLE TO BUYER OR ANY OTHER PERSON OR ENTITY FOR ANY EXTRA COSTS, EXPENSES, LOSSES, LOSS OF PROFITS, OR ANY INCIDENTAL, CONSEQUENTIAL OR SPECIAL DAMAGES RESULTING FROM ANY PRODUCT DEFECT OR FROM THE USE OR INABILITY TO USE THE PRODUCT, WHETHER ARISING IN CONTRACT OR WARRANTY, STATUTE, TORT, STRICT LIABILITY, NEGLIGENCE, OR OTHERWISE.**

Banner Engineering Corp. reserves the right to change, modify or improve the design of the product without assuming any obligations or liabilities relating to any product previously manufactured by Banner Engineering Corp. Any misuse, abuse, or improper application or installation of this product or use of the product for personal protection applications when the product is identified as not intended for such purposes will void the product warranty. Any modifications to this product without prior express approval by Banner Engineering Corp will void the product warranties. All specifications published in this document are subject to change; Banner reserves the right to modify product specifications or update documentation at any time. Specifications and product information in English supersede that which is provided in any other language. For the most recent version of any documentation, refer to: www.bannerengineering.com.

For patent information, see www.bannerengineering.com/patents.

ANATEL

Modelo (Model): DX80-2400—Este equipamento não tem direito à proteção contra interferência prejudicial e não pode causar interferência em sistemas devidamente autorizados. Para maiores informações, consulte o site da ANATEL www.gov.br/anatel/pt-br/

