

# VS8 Series Sensor Instruction Manual



Original Instructions  
p/n: 201958 Rev D  
May 19, 2023

© Banner Engineering Corp. All rights reserved.

# Contents

## Chapter 1 Product Description

VS8 Opposed Mode Models .....	3
VS8 Retroreflective Models .....	3
VS8 Background Suppression Models .....	4
VS8 Overview .....	5

## Chapter 2 Sensor Installation

Wiring Diagrams .....	7
-----------------------	---

## Chapter 3 VS8 Sensor Configuration

VS8 Remote Configuration – 4-Pin Models .....	9
VS8 Two-Point Static Background Suppression .....	9
VS8 One-Point Static Background Suppression .....	10
VS8 Dynamic Background Suppression.....	11
VS8 Two-Point Static Opposed and Retroreflective .....	12
VS8 Dynamic Opposed and Retroreflective .....	13
VS8 Select Light Operate/Dark Operate – 4-Pin Models .....	14

## Chapter 4 VS8 Specifications

VS8 Dimensions .....	16
VS8 Series Beam Spot Sizes .....	17
VS8 Minimum Object Separation (Background Suppression Models) .....	19

## Chapter 5 Accessories

Cordsets for VS8 Models with Suffix Q .....	21
Cordsets for VS8 Models with Suffix Q3 .....	21
Cordsets for VS8 Models with Suffix Q5 .....	22
Brackets .....	22
Retroreflectors .....	23

## Chapter 6 Banner Engineering Corp Limited Warranty

Document Information .....	25
----------------------------	----

Chapter Contents

VS8 Opposed Mode Models ..... 3  
 VS8 Retroreflective Models ..... 3  
 VS8 Background Suppression Models ..... 4  
 VS8 Overview ..... 5

# Chapter 1 Product Description

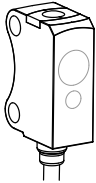

- Miniature sensor for installation in the smallest of spaces
- Red laser models provide bright, precise laser light spot for optimum small part detection
- High switching frequency for detection in even the fastest processes
- User-friendly operation using electronic push button or remote input provides reliable and precise detection
- Red laser, Red LED, and Blue LED types available to match sensing beam to application
- Robust, glass-fiber-reinforced plastic housing
- PNP or NPN output, depending on model

**WARNING:**



- **Do not use this device for personnel protection**
- Using this device for personnel protection could result in serious injury or death.
- This device does not include the self-checking redundant circuitry necessary to allow its use in personnel safety applications. A device failure or malfunction can cause either an energized (on) or de-energized (off) output condition.

## VS8 Opposed Mode Models

Model	Sensing Mode	Range	Output	Connection
VS8LEJ	Red Laser Emitter with Beam Inhibit	0 m to 3 m (0 in to 9.8 ft)	–	2 m (6.5 ft) unterminated 4-wire PUR cable
VS8LEJQ			–	200 mm (7.8 in) PUR cable with a 4-pin M8/Pico-style male quick disconnect (QD)
VS8EAPR	Receiver		PNP	2 m (6.5 ft) unterminated 4-wire PUR cable
VS8EANR				
VS8EAPRQ			PNP	200 mm (7.8 in) PUR cable with a 4-pin M8/Pico-style male quick disconnect (QD)
VS8EANRQ				

## VS8 Retroreflective Models

Model	Sensing Mode	Range	Output	Connection
VS8EAPLP	Red LED Retro Reflective	0.1 m to 1.6 m (3.9 in to 62.9 in) with BRT-2X2	PNP	2 m (6.5 ft) unterminated 4-wire PUR cable
VS8EANLP			NPN	
VS8EAPLPQ			PNP	200 mm (7.8 in) PUR cable with a 4-pin M8/Pico-style male quick disconnect (QD)
VS8EANLPQ			NPN	

Continued on page 4

Continued from page 3

Model	Sensing Mode	Range	Output	Connection
VS8EAPLLP	Red Laser Retro Reflective	0.1 m to 2 m (3.9 in to 78.7 in) with BRT-51X51BM	PNP	2 m (6.5 ft) unterminated 4-wire PUR cable
VS8EANLLP			NPN	
VS8EAPLLPQ			PNP	200 mm (7.8 in) PUR cable with a 4-pin M8/Pico-style male quick disconnect (QD)
VS8EANLLPQ			NPN	

## VS8 Background Suppression Models

Model	Sensing Mode	Range	Output
VS8EAPAF70	Red LED, Adjustable Background Suppression	5 mm to 70 mm (0.2 in to 2.8 in)	PNP
VS8EANAF70			NPN
VS8EAPLAF70	Red Laser, Adjustable Background Suppression	6 mm to 70 mm (0.24 in to 2.8 in)	PNP
VS8EANLAF70			NPN
VS8APFF30B	Blue LED, Fixed 30 mm Background Suppression	2 mm to 30 mm (0.08 in to 1.18 in)	PNP
VS8ANFF30B			NPN
VS8APFF50B	Blue LED, Fixed 50 mm Background Suppression	2 mm to 50 mm (0.08 in to 1.97 in)	PNP
VS8ANFF50B			NPN

Model	Sensing Mode	Range	Output
VS8APFF15	Red LED, Fixed 15 mm Background Suppression	2 mm to 15 mm (0.08 in to 0.59 in)	PNP
VS8ANFF15			NPN
VS8APFF30	Red LED, Fixed 30 mm Background Suppression	2 mm to 30 mm (0.08 in to 1.18 in)	PNP
VS8ANFF30			NPN
VS8APFF50	Red LED, Fixed 50 mm Background Suppression	2 mm to 50 mm (0.08 in to 1.97 in)	PNP
VS8ANFF50			NPN

Integral 2 m (6.5 ft) unterminated PUR cable models are listed.

- To order the 200 mm (7.8 in) PUR cable model with a 4-pin M8 quick disconnect, add suffix "Q" to the model number. AF and LAF models only.
- To order the 200 mm (7.8 in) PUR cable model with a 3-pin M8 quick disconnect, add suffix "Q3" to the model number. FF models only.
- To order the 200 mm (7.8 in) PUR cable model with a 4-pin M12 quick disconnect, add suffix "Q5" to the model number. AF and LAF models only.

## VS8 Overview

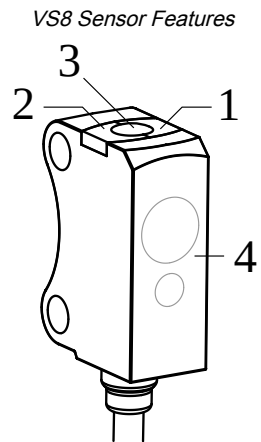

### **Features**

1. Green Indicator
2. Amber Indicator
3. TEACH Button - Laser Adjustable Field (LAF), Adjustable Field (AF), Polar Retro (LP), and Receiver (R) Models
4. Optical Window

*Blank page*

# Chapter 2 Sensor Installation

Install the sensor so the object to be detected moves horizontally to the sensor.

*VS8 Sensor Installation*

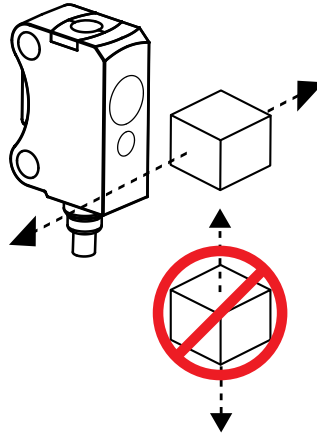

## Wiring Diagrams

<p><b>3-Pin NPN Models</b></p>	<p><b>3-Pin PNP Models</b></p>	<p><b>Key</b></p> <ul style="list-style-type: none"> <li>1. Brown</li> <li>2. White</li> <li>3. Blue</li> <li>4. Black</li> </ul>
<p><b>4-Pin NPN Models</b></p>	<p><b>4-Pin PNP Models</b></p>	<p><b>Opposed Mode Emitters</b></p>
<p><b>NOTE:</b> All 4-pin and cabled models have a remote input on the white wire (pin-2).</p>		

*Blank page*



Chapter Contents

VS8 Remote Configuration – 4-Pin Models ..... 9  
 VS8 Two-Point Static Background Suppression ..... 9  
 VS8 One-Point Static Background Suppression ..... 10  
 VS8 Dynamic Background Suppression ..... 11  
 VS8 Two-Point Static Opposed and Retroreflective ..... 12  
 VS8 Dynamic Opposed and Retroreflective ..... 13  
 VS8 Select Light Operate/Dark Operate – 4-Pin Models ..... 14

## Chapter 3 VS8 Sensor Configuration

- Expert™ 4-pin background suppression, retroreflective, and opposed mode receiver models are configurable using either the sealed push button or the remote input wire.
- 3-pin fixed field and opposed mode emitter models require no user adjustments.
- The remote input wire (pin-2/white wire) is used to select light or dark operate or perform the desired TEACH method. Pulse durations for the remote input wire correspond to the indicated press durations of the push button.

### VS8 Remote Configuration – 4-Pin Models

The remote input wire (pin-2/white wire) is used to select light or dark operate, or perform the desired TEACH method. Closing and opening times for the remote input wire correspond to the indicated press/hold durations of the push button.

### VS8 Two-Point Static Background Suppression

Two-point TEACH sets a single switch point. The sensor sets the switch point between two taught target distances, relative to the shifted origin location.

1. Present the target.

Method	Action		Result
Push Button	Present the first target. The sensor-to-target distance must be within the sensor's range.		N/A
Remote Input			

2. Start TEACH mode.

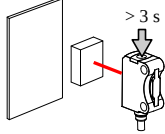
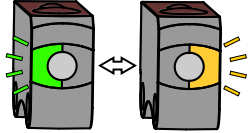
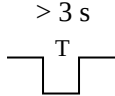
Method	Action		Result
Push Button	Press and hold push button > 3 seconds.		 Both LEDs flash (alternating)
Remote Input	Pulse remote input wire > 3 seconds.		

3. Present the background or second target.

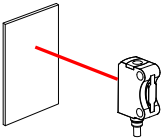
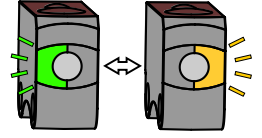
Method	Action		Result
Push Button	Present the background or second target. The sensor-to-target distance must be within the sensor's range.		 Both LEDs flash (alternating)
Remote Input			

4. Configure the sensor.

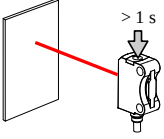
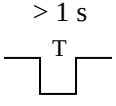
Method	Action		Result
Push Button	Press push button > 1 second.		Sensor returns to normal operation.
Remote Input	Pulse remote input wire > 1 second.		

## VS8 One-Point Static Background Suppression

One-point TEACH sets a single switch point. The sensor sets the switch point just behind the taught target distance.

1. Present the target.

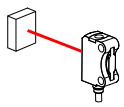
Method	Action		Result
Push Button	Present the target. The sensor-to-target distance must be within the sensor's range.		N/A
Remote Input			

2. Start TEACH mode.

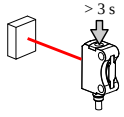
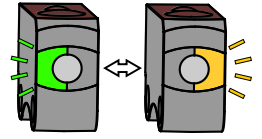
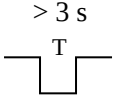
Method	Action		Result
Push Button	Press and hold push button > 3 seconds.		 Both LEDs flash (alternating)
Remote Input	Pulse remote input wire > 3 seconds.		

3. Configure the sensor.

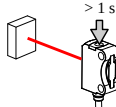
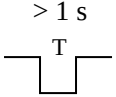
Method	Action		Result
<b>Push Button</b>	Press push button > 1 second.		Sensor returns to normal operation.
<b>Remote Input</b>	Pulse remote input wire > 1 second.		

## VS8 Dynamic Background Suppression

Dynamic TEACH sets a single switch point during machine run conditions. Dynamic TEACH is recommended for applications where a machine or process may not be stopped for teaching. The sensor takes multiple samples and the switch point is set just behind the farthest taught target distance, accounting for a static background.

1. Present the target.

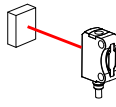
Method	Action		Result
<b>Push Button</b>	Present the first target. The sensor-to-target distance must be within the sensor's range.		N/A
<b>Remote Input</b>			

2. Start TEACH mode.

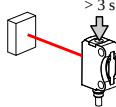
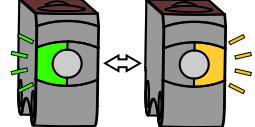
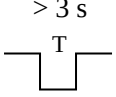
Method	Action		Result
<b>Push Button</b>	Press and hold push button > 3 seconds.		 Both LEDs flash (alternating)
<b>Remote Input</b>	Pulse remote input wire > 3 seconds.		

3. Configure the sensor.

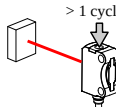
Method	Action		Result
<b>Push Button</b>	Press and hold push button > 1 cycle of operation.		Sensor returns to normal operation.

Continued on page 12

Continued from page 11

Method	Action		Result
Remote Input	Pulse remote input wire > 1 cycle of operation.	<p>&gt; 1 cycle</p> 	

## VS8 Two-Point Static Opposed and Retroreflective

Two-point TEACH for Opposed and Retroreflective modes sets a single switching level. The sensor sets the switching level between the blocked and unblocked conditions.

1. Align the sensor.

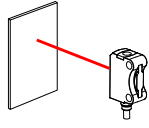
Method	Action		Result
Push Button	Align the emitter/receiver or sensor/retroreflector. The beam path should not be blocked.		N/A
Remote Input			

2. Start TEACH mode.

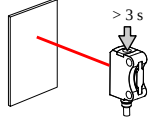
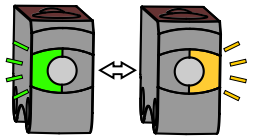
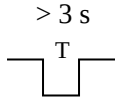
Method	Action		Result
Push Button	Press and hold push button > 3 seconds.		 <p>Both LEDs flash (alternating)</p>
Remote Input	Pulse remote input wire > 3 seconds.	<p>&gt; 3 s</p> 	

3. Present the target.

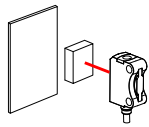
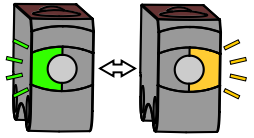
Method	Action		Result
Push Button	Present the target. The beam path should be blocked by the target.		 <p>Both LEDs flash (alternating)</p>
Remote Input			

4. Configure the sensor.

Method	Action		Result
Push Button	Press and hold push button > 1 second.		Sensor returns to normal operation.

Continued on page 13

Continued from page 12

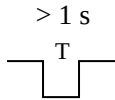
Method	Action		Result
Remote Input	Pulse remote input wire > 1 second.		

## VS8 Dynamic Opposed and Retroreflective

Dynamic TEACH for Opposed and Retroreflective modes sets a single switching level during machine run conditions. Dynamic TEACH is recommended for applications where a machine or process may not be stopped for teaching. The sensor takes multiple samples and the switching level is set between the blocked and unblocked conditions.

1. Present the target.

Method	Action		Result
Push Button	Present the target. The beam path should be blocked by the target.		N/A
Remote Input			

2. Start TEACH mode.

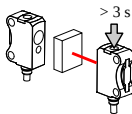
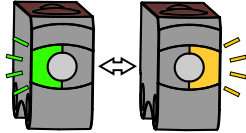
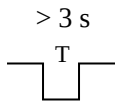
Method	Action		Result
Push Button	Press and hold push button > 3 seconds.		 Both LEDs flash (alternating)
Remote Input	Pulse remote input wire > 3 seconds.		

3. Configure the sensor.

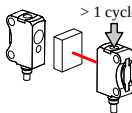
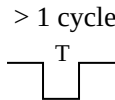
Method	Action		Result
Push Button	Press and hold push button > 1 cycle of operation.		Sensor returns to normal operation.
Remote Input	Pulse remote input wire > 1 cycle of operation.		

## VS8 Select Light Operate/Dark Operate – 4-Pin Models

Change the sensor operation to light operate or dark operate for the desired application. Use either the button or the remote input wire procedure to configure the sensor.

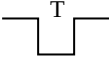
Method	Action		Result
<b>Push Button</b>	Press and hold the button for longer than 10 seconds. Press the button until the desired operation is selected, then release the button and wait 10 seconds.	<p>&gt; 10 s</p> 	The green LED flashes to show that the sensor is in LO/DO select mode.
			The amber LED indicates the selected operation mode.
<b>Remote Input Wire</b>	Pulse the remote input wire to + V DC for longer than 10 seconds. Pulse the remote input wire to + V DC for 4 to 1000 ms until the desired operation is selected and wait 10 seconds.	<p>4-1000 ms</p> 	<p>For light operate: The green LED flashes and the amber LED is off. For dark operation: The green LED flashes and the amber LED is on.</p> <p>The sensor is configured and returns to normal operation.</p>

Chapter Contents

VS8 Dimensions ..... 16  
 VS8 Series Beam Spot Sizes ..... 17  
 VS8 Minimum Object Separation (Background Suppression Models)..... 19

# Chapter 4 VS8 Specifications

**Laser Classifications**

All Models: Class 1; wavelength: 655 nm; frequency: 5 kHz; pulse duration: 3.2 μs; limit value pulse: ≤ 2.3 mW. Reference IEC 60825-1:2001, Section 8.2.

All Models: Complies with 21 CFR 1040.10 and 1040.11 except for deviations pursuant to laser Notice No. 50 dated June 24, 2007.

Blue LED Models: Risk Group 2; possibly hazardous optical radiation emitted from this product. Do not stare at the operating lamp. May be harmful to the eyes. (EN62471)

**Certifications**



**Banner Engineering BV** Park Lane, Culliganlaan 2F bus 3, 1831 Diegem, BELGIUM



**Turck Banner LTD** Blenheim House, Blenheim Court, Wickford, Essex SS11 8YT, Great Britain



**Supply Voltage and Current**

LED models: 10 V DC to 30 V DC (10% max. ripple) at less than 20 mA, exclusive of load

Laser models: 10 V DC to 30 V DC (10% max. ripple) at less than 12 mA, exclusive of load

**Supply Protection Circuitry**

Protected against reverse polarity and short-circuit

**Output Protection Circuitry**

Protected against output short-circuit, continuous overload, and false pulse on power-up

**Output Configuration**

Retroreflective and Background Suppression Models: Single PNP or NPN on pin 4 (black wire) with remote input on pin 2 (white wire)

Opposed Mode Receivers only: Single PNP or NPN on pin 4 (black wire) with remote input on pin 2 (white wire)

**Output Response Time**

500 μs

**Output Rating**

50 mA

**Switching Frequency**

≤ 1000 Hz

**Delay Before Power-Up**

< 300 ms

**Required Overcurrent Protection**



**WARNING:** Electrical connections must be made by qualified personnel in accordance with local and national electrical codes and regulations.

Overcurrent protection is required to be provided by end product application per the supplied table.

Overcurrent protection may be provided with external fusing or via Current Limiting, Class 2 Power Supply.

Supply wiring leads < 24 AWG shall not be spliced.

For additional product support, go to [www.bannerengineering.com](http://www.bannerengineering.com).

Supply Wiring (AWG)	Required Overcurrent Protection (A)	Supply Wiring (AWG)	Required Overcurrent Protection (A)
20	5.0	26	1.0
22	3.0	28	0.8
24	1.0	30	0.5

**Indicators**

2 LED indicators on top of the sensor

Green on: Power on

Amber on: Output conducting

**Emitter LED Wavelength**

Red LED models: 650 nm

Blue LED models: 450 nm

Laser models: 655 nm

**Effective Beam**

5.5 mm

This can be adjusted without an aperture by teaching the sensor

**Connections**

2 m (6.5 ft) unterminated 4-wire PUR cable or 200 mm (7.8 in) PUR cable with a 3- or 4-pin M8 or 4-pin M12 male quick disconnect, depending on model

Models ending in suffix "Q", "Q3", or "Q5" must be used with a UL recognized cordset R/C (CYJV2)

Search p/n 201958 at [www.bannerengineering.com](http://www.bannerengineering.com) to view the Instruction Manual for more information on cordsets

**Opposed Mode Model Adjustments**

Push button TEACH input (Receivers)

Remote wire TEACH input (Receivers)

Remote wire beam inhibit (Emitters)

**Construction**

Housing, cable: PUR  
 Front screen: PMMA

**Chemical Compatibility**

ECOLAB® certified (2 m cabled models only)

**Operating Conditions**

LED models: -20 °C to +60 °C (-4 °F to +140 °F)  
 Laser models: -20 °C to +50 °C (-4 °F to +122 °F)  
 Storage Temperature: -20 °C to +80 °C (-4 °F to +176 °F)  
 UL Operating Temperature: -20 °C to +30 °C (-4 °F to +86 °F)

**Environmental Rating**

IP67

## VS8 Dimensions

All measurements are listed in millimeters [inches], unless noted otherwise.

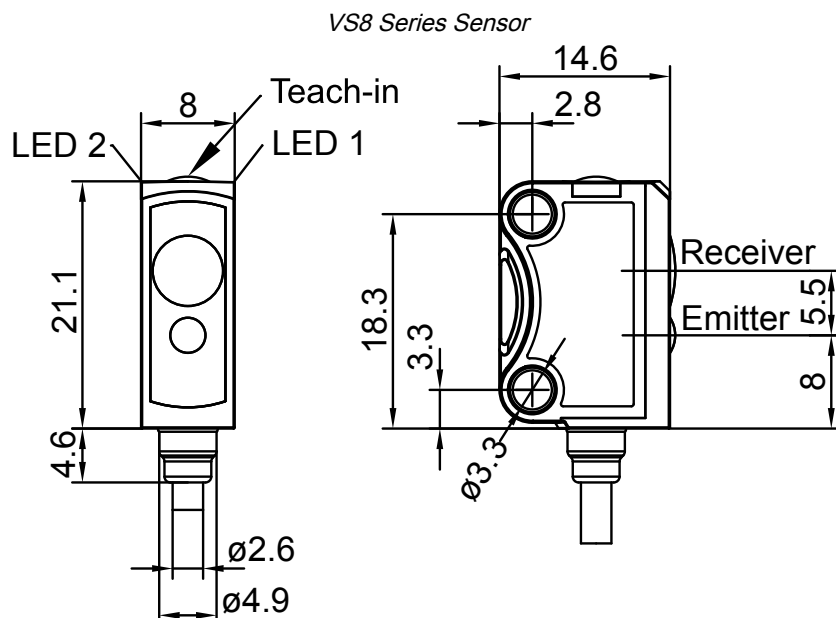



VS8 Series Sensor with SMBVS8DT Bracket

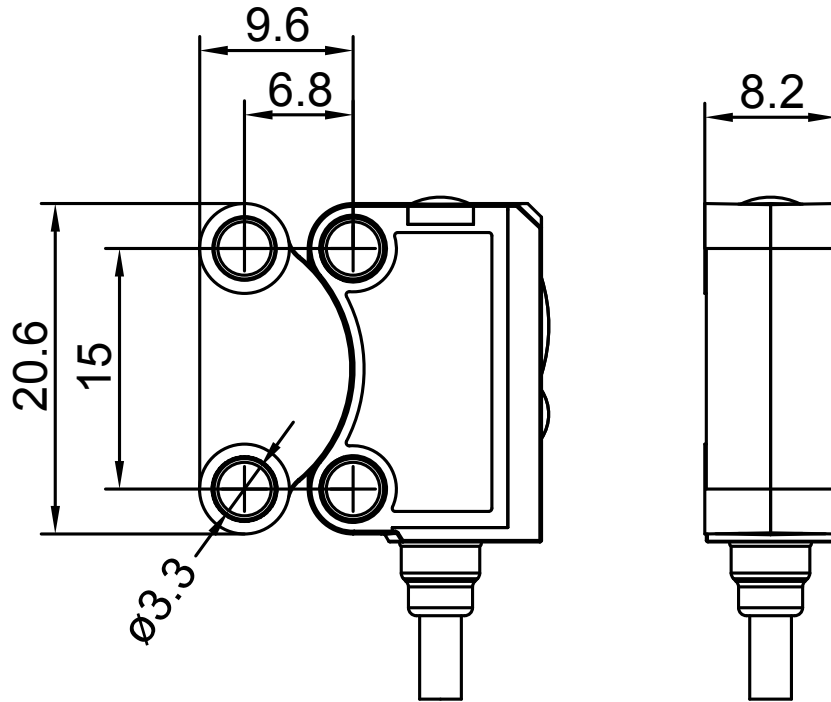

## VS8 Series Beam Spot Sizes

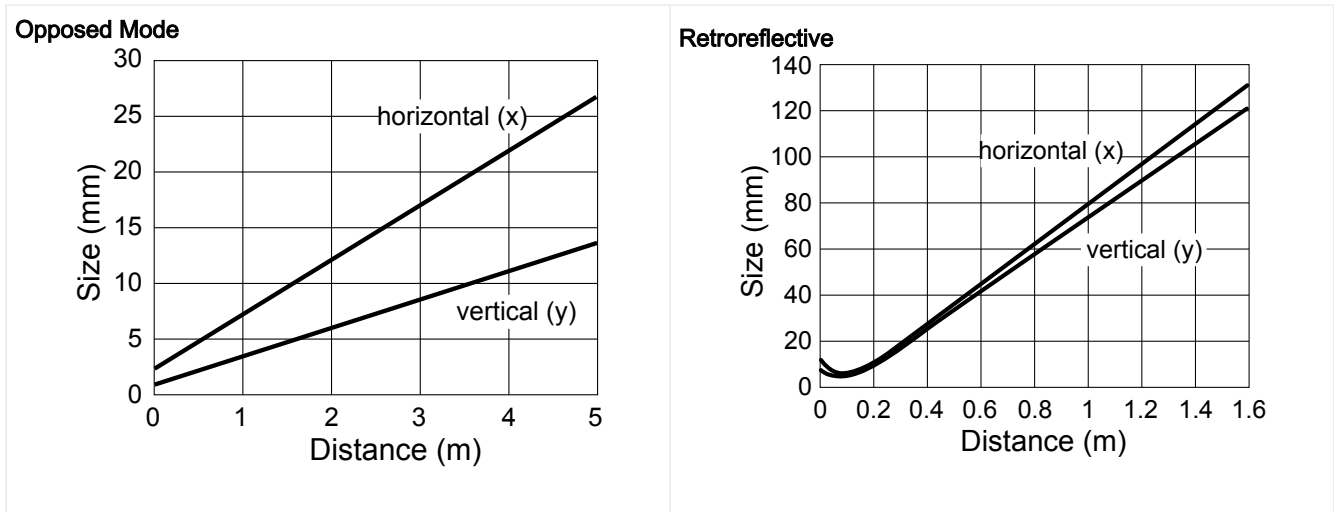

Continued on page 18

Continued from page 17

**Laser Retroreflective**

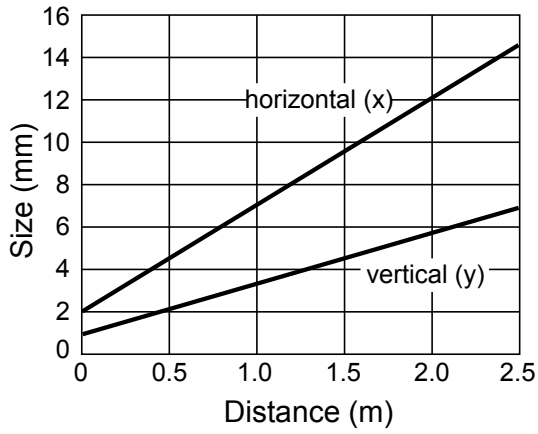

**Fixed Field Background Suppression with Blue LED**

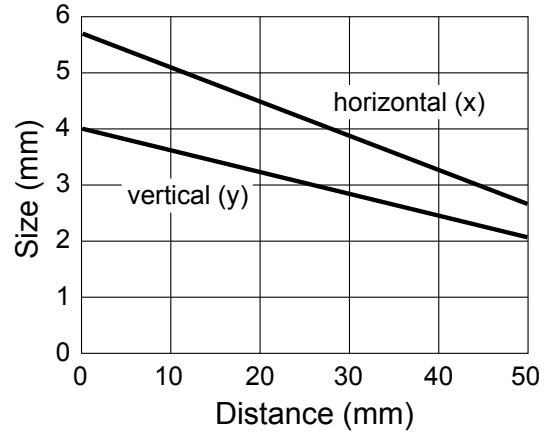

**Fixed Field Background Suppression**

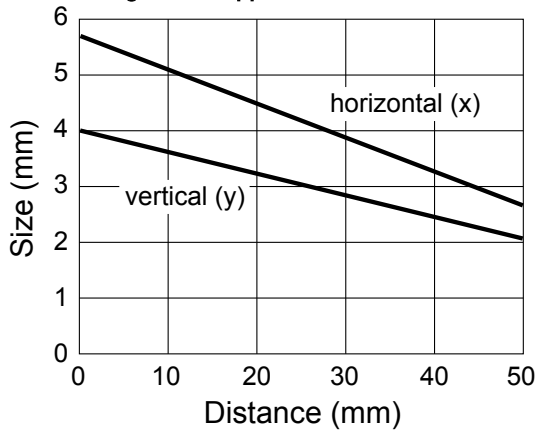

**Adjustable Field Background Suppression**

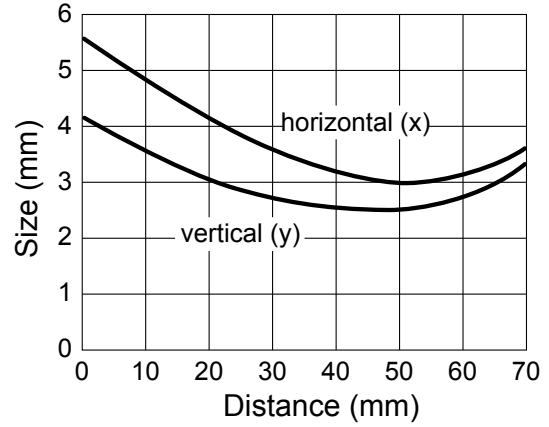

**Laser Adjustable Field Background Suppression**

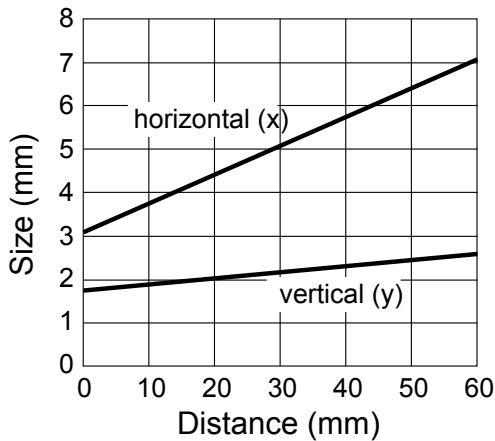

# VS8 Minimum Object Separation (Background Suppression Models)

*Minimum object separation for laser sensor models with background suppression*

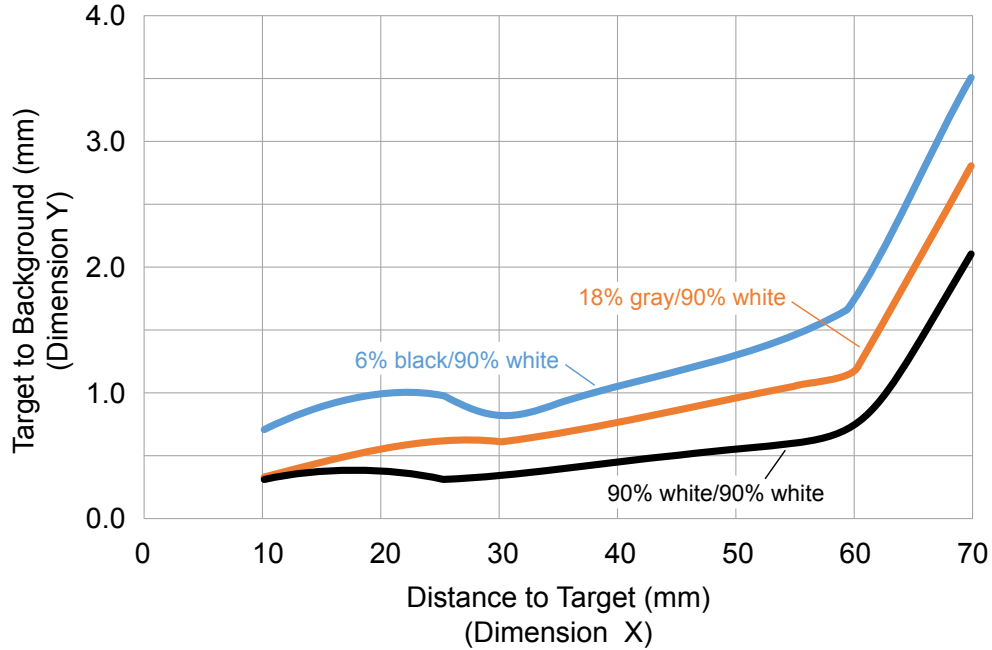

*Minimum object separation for LED sensor models with background suppression*

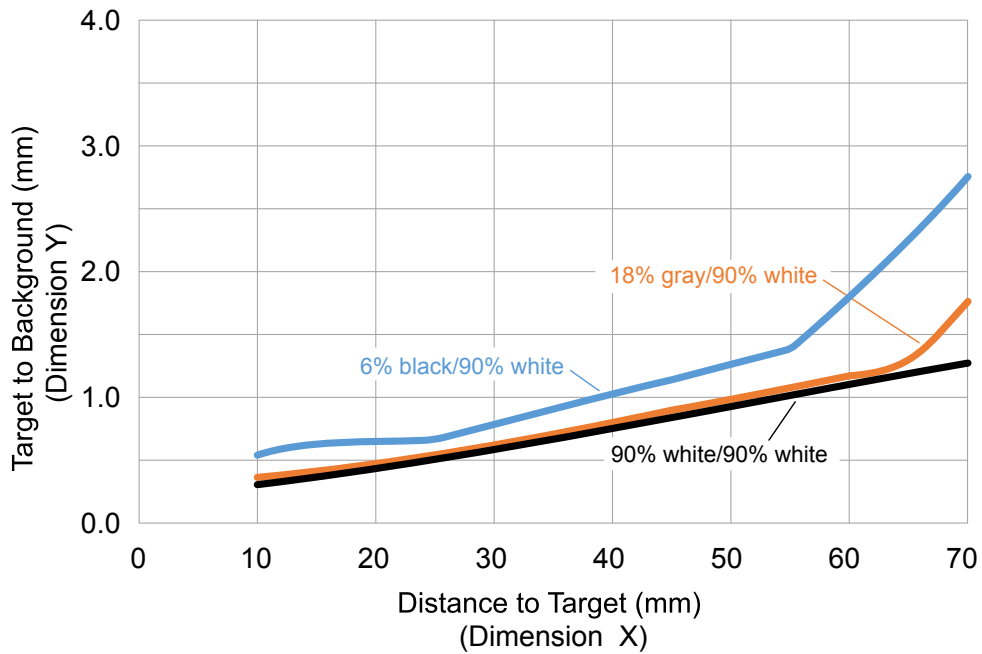

*Blank page*

Chapter Contents

Cordsets for VS8 Models with Suffix Q ..... 21  
 Cordsets for VS8 Models with Suffix Q3 ..... 21  
 Cordsets for VS8 Models with Suffix Q5 ..... 22  
 Brackets ..... 22  
 Retroreflectors ..... 23

# Chapter 5 Accessories

## Cordsets for VS8 Models with Suffix Q

All measurements are listed in millimeters, unless noted otherwise.

4-Pin Threaded M8 Cordsets—Single Ended				
Model	Length	Style	Dimensions	Pinout (Female)
PKG4M-2	2.04 m (6.68 ft)	Straight		
PKG4M-5	5 m (16.4 ft)			
PKG4M-9	9.04 m (29.6 ft)			
PKW4M-2	2 m (6.56 ft)	Right Angle		
PKW4M-5	5 m (16.4 ft)			
PKW4M-9	9 m (29.5 ft)			

1 = Brown  
 2 = White  
 3 = Blue  
 4 = Black

## Cordsets for VS8 Models with Suffix Q3

3-pin Threaded M8 Cordsets—Single Ended				
Model	Length	Style	Dimensions	Pinout (Female)
PKG3M-2	2.035 m (6.68 ft)	Straight		
PKG3M-5	5.035 m (16.51 ft)			
PKG3M-7	7.035 m (23.08 ft)			
PKG3M-9	9.035 m (29.64 ft)			
PKW3M-2	2 m (6.56 ft)	Right-Angle		
PKW3M-5	5 m (16.40 ft)			
PKW3M-9	9 m (29.53 ft)			

1 = Brown  
 3 = Blue  
 4 = Black

# Cordsets for VS8 Models with Suffix Q5

All measurements are listed in millimeters, unless noted otherwise.

## 4-Pin Threaded M12 Cordsets

**Cable:** PVC jacket, PUR (polyurethane) connector body, nickel-plated brass coupling nut

**Conductors:** 22 AWG, gold-plated contacts

**Conductors:** 22 AWG, gold-plated contacts

**Voltage/Current Rating:** 250 V AC/DC, 4.0 A

**Temperature:**

**Environmental Rating:** IP67/IP69K

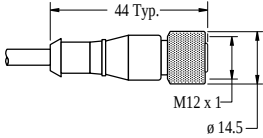
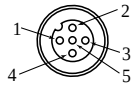
4-Pin Threaded M12 Cordsets—Single Ended					
Model	Length	Style	Dimensions	Pinout (Female)	
MQDC-403	1 m (3.28 ft)	Straight			1 = Brown 2 = White 3 = Blue 4 = Black 5 = Not used
MQDC-406	2 m (6.56 ft)				
MQDC-410	3 m (9.8 ft)				
MQDC-415	5 m (16.4 ft)				
MQDC-430	9 m (29.5 ft)				
MQDC-450	15 m (49.2 ft)				
MQDC-460	18.3 m (60 ft)				
MQDC-470	21 m (68.9 ft)				
MQDC-4100	30 m (98.43 ft)				

## Brackets

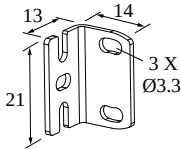
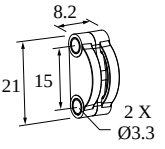
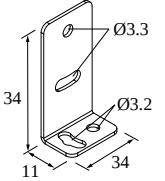
<p><b>SMBVS8RA</b></p> <ul style="list-style-type: none"> <li>• Right-angle bracket</li> <li>• 3.1 mm stainless steel</li> </ul>	
<p><b>SMBVS8DT</b></p> <ul style="list-style-type: none"> <li>• Dovetail clamp bracket</li> <li>• Adjustable ± 10°</li> <li>• Material: PBT</li> </ul>	
<p><b>SMBQ12A</b></p> <ul style="list-style-type: none"> <li>• Adjustable right-angle bracket</li> <li>• 20-ga. 300 series stainless steel</li> </ul> <p><b>Hole center spacing:</b> A to B = 7.6</p> <p><b>Hole size:</b> A = 3.5 x 8.1, B = ø 3.2</p>	

<p><b>SMBQ12T</b></p> <ul style="list-style-type: none"> <li>• Right-angle bracket</li> <li>• 20-ga. 300 series stainless steel</li> </ul> <p><b>Hole center spacing:</b> A to B = 7.6</p> <p><b>Hole size:</b> A = 3.5 x 8.1, B = <math>\varnothing</math> 3.2</p>	
---	--

<p><b>SMBQ20FA</b></p> <ul style="list-style-type: none"> <li>• Includes 3/8-16 x 2 in socket head cap screw (SHCS)</li> <li>• 304 stainless steel</li> </ul>	
---	--

## Retroreflectors

<p><b>BRT-10BM</b></p> <ul style="list-style-type: none"> <li>• Round, acrylic target</li> <li>• Reflectivity Factor: 1.0</li> <li>• Temperature:</li> <li>• Micro-prism geometry</li> <li>• Size: 10 mm diameter</li> <li>• Reflective area: <math>\varnothing</math>10 mm</li> </ul>	
--	--

<p><b>BRT-35X35BM</b></p> <ul style="list-style-type: none"> <li>• Square, acrylic target</li> <li>• Reflectivity Factor: 1.2</li> <li>• Temperature: -20 °C to +60 °C (-4 °F to +140 °F)</li> <li>• Micro-prism geometry</li> <li>• Approximate size: 35 mm x 35 mm</li> </ul>	
---	--

<p><b>BRT-11X11M</b></p> <ul style="list-style-type: none"> <li>• Square, acrylic target</li> <li>• Reflectivity Factor: 1.2</li> <li>• Temperature:</li> <li>• Micro-prism geometry</li> <li>• Approximate size: 11 mm x 11 mm</li> </ul>	
--	--

<p><b>BRT-40X18A</b></p> <ul style="list-style-type: none"> <li>• Rectangular, acrylic target</li> <li>• Reflectivity Factor: 1.0</li> <li>• Temperature:</li> <li>• Approximate size: 18 mm x 50 mm</li> </ul>	
---	--

**NOTE:** For maximum adhesion of all tape products, surfaces must be clean.

Model	Reflectivity Factor	Maximum Temperature	Size
BRT-THG-2-100	0.7	+60 °C (+140 °F)	50 mm (2 in) wide, 2.5 m (100 in) long



## Chapter 6      Banner Engineering Corp Limited Warranty

---

Banner Engineering Corp. warrants its products to be free from defects in material and workmanship for one year following the date of shipment. Banner Engineering Corp. will repair or replace, free of charge, any product of its manufacture which, at the time it is returned to the factory, is found to have been defective during the warranty period. This warranty does not cover damage or liability for misuse, abuse, or the improper application or installation of the Banner product.

**THIS LIMITED WARRANTY IS EXCLUSIVE AND IN LIEU OF ALL OTHER WARRANTIES WHETHER EXPRESS OR IMPLIED (INCLUDING, WITHOUT LIMITATION, ANY WARRANTY OF MERCHANTABILITY OR FITNESS FOR A PARTICULAR PURPOSE), AND WHETHER ARISING UNDER COURSE OF PERFORMANCE, COURSE OF DEALING OR TRADE USAGE.**

This Warranty is exclusive and limited to repair or, at the discretion of Banner Engineering Corp., replacement. **IN NO EVENT SHALL BANNER ENGINEERING CORP. BE LIABLE TO BUYER OR ANY OTHER PERSON OR ENTITY FOR ANY EXTRA COSTS, EXPENSES, LOSSES, LOSS OF PROFITS, OR ANY INCIDENTAL, CONSEQUENTIAL OR SPECIAL DAMAGES RESULTING FROM ANY PRODUCT DEFECT OR FROM THE USE OR INABILITY TO USE THE PRODUCT, WHETHER ARISING IN CONTRACT OR WARRANTY, STATUTE, TORT, STRICT LIABILITY, NEGLIGENCE, OR OTHERWISE.**

Banner Engineering Corp. reserves the right to change, modify or improve the design of the product without assuming any obligations or liabilities relating to any product previously manufactured by Banner Engineering Corp. Any misuse, abuse, or improper application or installation of this product or use of the product for personal protection applications when the product is identified as not intended for such purposes will void the product warranty. Any modifications to this product without prior express approval by Banner Engineering Corp will void the product warranties. All specifications published in this document are subject to change; Banner reserves the right to modify product specifications or update documentation at any time. Specifications and product information in English supersede that which is provided in any other language. For the most recent version of any documentation, refer to: [www.bannerengineering.com](http://www.bannerengineering.com).

For patent information, see [www.bannerengineering.com/patents](http://www.bannerengineering.com/patents).

## Document Information

Document title: VS8 Series Sensor with Background Suppression Instruction Manual

Part number: 201958

Revision: D

Original Instructions

© Banner Engineering Corp. All rights reserved.



 [LinkedIn](#)

 [Twitter](#)

 [Facebook](#)

