

# RS-232 Converter: Model INT-BBB-X232Q5



## Datasheet

Converter for Banner Bus communications to RS-232



Maintain high resolution distance measurements with digital export via RS-232



**WARNING:**

- Do not use this device for personnel protection
- Using this device for personnel protection could result in serious injury or death.
- This device does not include the self-checking redundant circuitry necessary to allow its use in personnel safety applications. A device failure or malfunction can cause either an energized (on) or de-energized (off) output condition.

## Models

Model	Adaptor	Connection
INT-BBB-X232Q5	RS-232 to BANNER Bus	150 mm (6 in) PVC cable with a 5-pin M12/Euro-style quick disconnect

## Installation Options

**Key**

- A = RS-232 Converter (INT-BBB-X232Q5)
- B = Splitter (CSB-M1241DB9)
- C = PC
- D = Banner LM Series Sensor with RS232
- E = Flying lead 5 pin MQDC-5xx cable

**Option One: Full Preview Capabilities Setup (Recommended)**

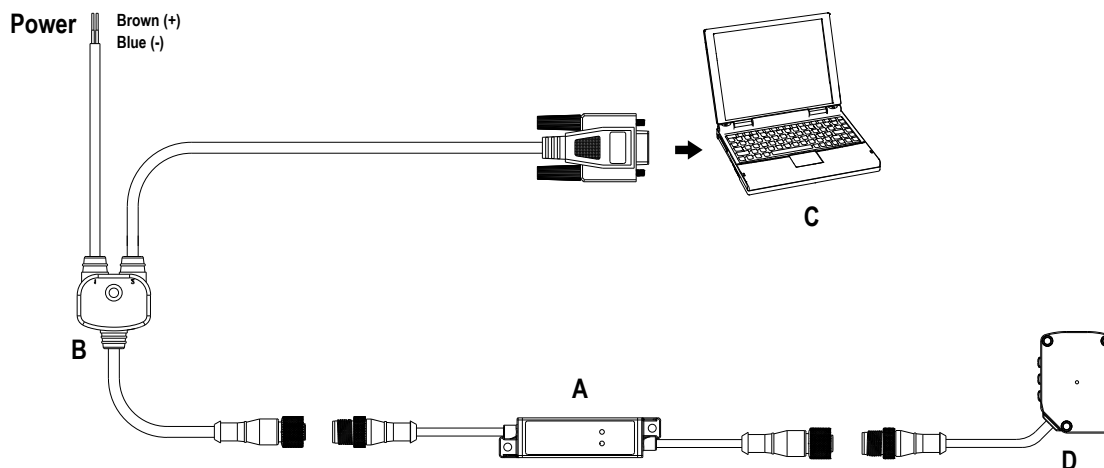

**Option Two: Cable with Flying Leads**

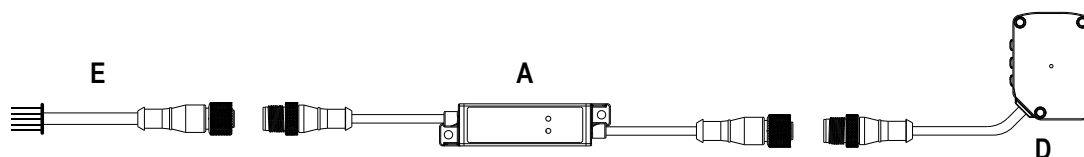

## Specifications

### Supply Voltage

10 V DC to 30 V DC

### Power and Current Consumption, exclusive of load

Normal Run Mode: 0.48 W, current consumption < 20 mA at 24 V DC

### Supply Protection Circuitry

Protected against reverse polarity and transient overvoltages

### RS-232 COM Port Settings

38400 Baud  
8 Data Bits  
1 Stop Bit  
No Parity

### Indicators

Two LED indicators:

Green = Power On

Amber = RS232 Communication Active

### Connections

150 mm (6 in) PVC cable with a 5-pin M12/Euro-style quick disconnect

### Communications

RS232 ASCII Communication to compatible Banner Pro-Series enabled devices

### Operating Conditions

-20 °C to +70 °C (-4 °F to +158 °F)

90% at +55 °C maximum relative humidity (non-condensing)

**Storage Temperature:** -40 °C to +120 °C (-40 °F to +248 °F)

For communications information, see p/n 219241 LM Serial Communications Guide available at [www.bannerengineering.com](http://www.bannerengineering.com).

## Dimensions

All measurements are listed in millimeters [inches], unless noted otherwise.

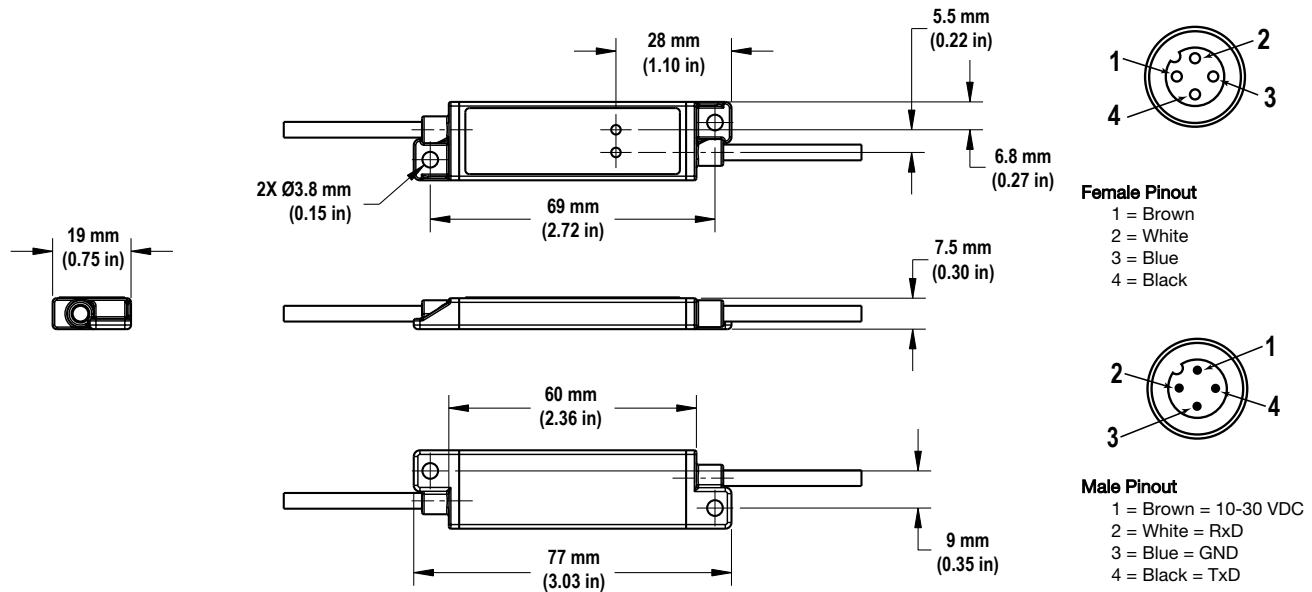

	Model Number	X (mm)	Y (mm)	Z (mm)
	INT-BBB-X232Q5	150	77	150

## Banner Engineering Corp. Limited Warranty

Banner Engineering Corp. warrants its products to be free from defects in material and workmanship for one year following the date of shipment. Banner Engineering Corp. will repair or replace, free of charge, any product of its manufacture which, at the time it is returned to the factory, is found to have been defective during the warranty period. This warranty does not cover damage or liability for misuse, abuse, or the improper application or installation of the Banner product.

**THIS LIMITED WARRANTY IS EXCLUSIVE AND IN LIEU OF ALL OTHER WARRANTIES WHETHER EXPRESS OR IMPLIED (INCLUDING, WITHOUT LIMITATION, ANY WARRANTY OF MERCHANTABILITY OR FITNESS FOR A PARTICULAR PURPOSE), AND WHETHER ARISING UNDER COURSE OF PERFORMANCE, COURSE OF DEALING OR TRADE USAGE.**

This Warranty is exclusive and limited to repair or, at the discretion of Banner Engineering Corp., replacement. **IN NO EVENT SHALL BANNER ENGINEERING CORP. BE LIABLE TO BUYER OR ANY OTHER PERSON OR ENTITY FOR ANY EXTRA COSTS, EXPENSES, LOSSES, LOSS OF PROFITS, OR ANY INCIDENTAL, CONSEQUENTIAL OR SPECIAL DAMAGES RESULTING FROM ANY PRODUCT DEFECT OR FROM THE USE OR INABILITY TO USE THE PRODUCT, WHETHER ARISING IN CONTRACT OR WARRANTY, STATUTE, TORT, STRICT LIABILITY, NEGLIGENCE, OR OTHERWISE.**

Banner Engineering Corp. reserves the right to change, modify or improve the design of the product without assuming any obligations or liabilities relating to any product previously manufactured by Banner Engineering Corp. Any misuse, abuse, or improper application or installation of this product or use of the product for personal protection applications when the product is identified as not intended for such purposes will void the product warranty. Any modifications to this product without prior express approval by Banner Engineering Corp will void the product warranties. All specifications published in this document are subject to change; Banner reserves the right to modify product specifications or update documentation at any time. Specifications and product information in English supersede that which is provided in any other language. For the most recent version of any documentation, refer to: [www.bannerengineering.com](http://www.bannerengineering.com).

For patent information, see [www.bannerengineering.com/patents](http://www.bannerengineering.com/patents).