

Datasheet



For complete technical information about this product, including installation instructions, application requirements and guidelines, technical specifications, dimensions, and accessories, please refer to the manual at www.bannerengineering.com. Scan the QR code or follow the link below to go to the product series web page, and search for the PVS28 Parts Verification Sensor manual, p/n 233619, in the Downloads. Use of this document assumes familiarity with pertinent industry standards and practices.
<https://www.bannerengineering.com/pvs28>



Wiring Diagrams

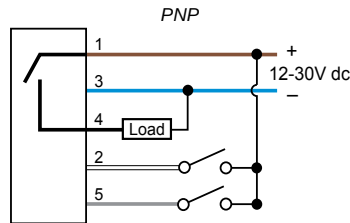
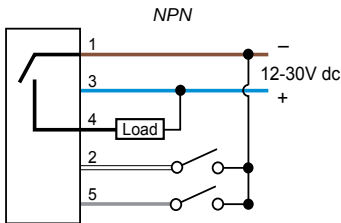

Pin 1 = Brown
 Pin 2 = White
 Pin 3 = Blue
 Pin 4 = Black
 Pin 5 = Gray (Remote Input)

Four-State Full Logic

Green	Input active, no detection
Yellow	Input active, detection
Red	No input, detection
Off	Power applied, but no input or detection

Models

PVS28D100QP: 28 mm width by 100 mm length, with Diffuse/Distance sensing mode and 150 mm (6 in.) PVC cable with 5-pin M12 quick-disconnect connector

PVS28D225QP: 28 mm width by 225 mm length, with Diffuse/Distance sensing mode and 150 mm (6 in.) PVC cable with 5-pin M12 quick-disconnect connector

Remote Teach

Use the following procedure to teach the Set Point.

- Pulse the remote input:
 - 3x - Object Teach: The indicator alternates between a blue Teach Status color and the Signal Level color.
 - 4x - Background Teach: The indicator alternates between a magenta Teach Status color and the Signal Level color.
 - 5x - Window Teach: The indicator alternates between a cyan Teach Status color and the Signal Level color.
 - 6x - Retroreflective Teach: The indicator performs a chase animation with a blue Teach Status color, with the Signal Level color as the background.
- Present the Set Point.
- Teach the Set Point.

Action		Result
Single pulse the remote input.		<p>Teach Accepted</p> <p>The indicator stops flashing and the device returns to operation.</p> <p>Teach Not Accepted</p> <p>The Signal Level color turns red during the teach procedure, and then the indicator stops flashing.</p> <p>Retry teaching the set point.</p>



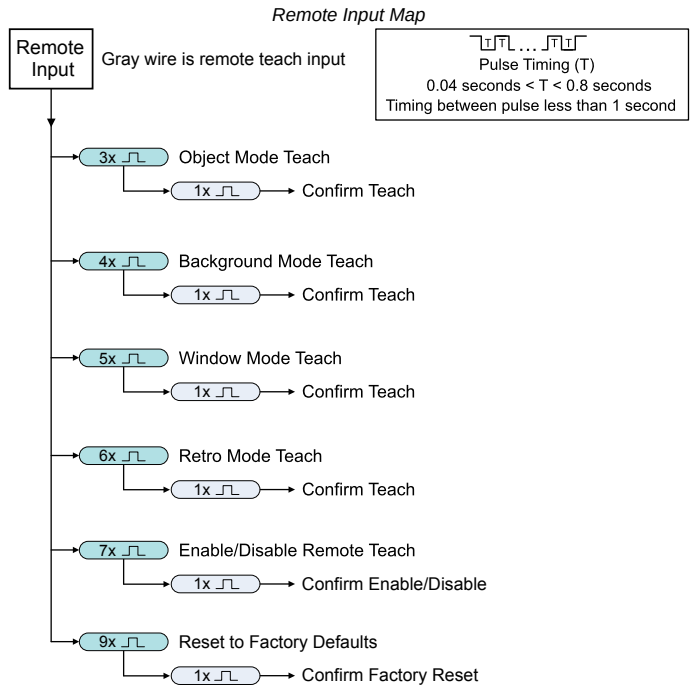

Specifications

Supply Voltage (Vcc)

12 V DC to 30 V DC

Supply Current

Maximum current (exclusive of load):

100 mm: 85 mA
225 mm: 150 mA

Range

The sensor can detect an object at the following ranges, depending on the material and size of the target: 20 mm to 500 mm

Application Note

For best performance, allow 5 minutes for the sensor to warm up

Operating Temperature

-20 °C to +50 °C (-4 °F to +122 °F)

Environmental Rating

IP54

Certifications



Key Accessories

Refer to the manual for additional accessories and complete information.

SMBPVA1

Included with PVS sensor

PRO-KIT

Pro Converter Cable
Splitter (CSB-M2151FM1251M)
Power Supply (PSW-24-1)

Retroreflective Tape

BRT-THG-1-100: 25 mm (1 in) wide
BRT-THG-2-100: 50 mm (2 in) wide
BRT-THG-3-100: 75 mm (3 in) wide

Banner Engineering Corp Limited Warranty

Banner Engineering Corp. warrants its products to be free from defects in material and workmanship for one year following the date of shipment. Banner Engineering Corp. will repair or replace, free of charge, any product of its manufacture which, at the time it is returned to the factory, is found to have been defective during the warranty period. This warranty does not cover damage or liability for misuse, abuse, or the improper application or installation of the Banner product.

THIS LIMITED WARRANTY IS EXCLUSIVE AND IN LIEU OF ALL OTHER WARRANTIES WHETHER EXPRESS OR IMPLIED (INCLUDING, WITHOUT LIMITATION, ANY WARRANTY OF MERCHANTABILITY OR FITNESS FOR A PARTICULAR PURPOSE), AND WHETHER ARISING UNDER COURSE OF PERFORMANCE, COURSE OF DEALING OR TRADE USAGE.

This Warranty is exclusive and limited to repair or, at the discretion of Banner Engineering Corp., replacement. **IN NO EVENT SHALL BANNER ENGINEERING CORP. BE LIABLE TO BUYER OR ANY OTHER PERSON OR ENTITY FOR ANY EXTRA COSTS, EXPENSES, LOSSES, LOSS OF PROFITS, OR ANY INCIDENTAL, CONSEQUENTIAL OR SPECIAL DAMAGES RESULTING FROM ANY PRODUCT DEFECT OR FROM THE USE OR INABILITY TO USE THE PRODUCT, WHETHER ARISING IN CONTRACT OR WARRANTY, STATUTE, TORT, STRICT LIABILITY, NEGLIGENCE, OR OTHERWISE.**

Banner Engineering Corp. reserves the right to change, modify or improve the design of the product without assuming any obligations or liabilities relating to any product previously manufactured by Banner Engineering Corp. Any misuse, abuse, or improper application or installation of this product or use of the product for personal protection applications when the product is identified as not intended for such purposes will void the product warranty. Any modifications to this product without prior express approval by Banner Engineering Corp will void the product warranties. All specifications published in this document are subject to change; Banner reserves the right to modify product specifications or update documentation at any time. Specifications and product information in English supersede that which is provided in any other language. For the most recent version of any documentation, refer to: www.bannerengineering.com.

For patent information, see www.bannerengineering.com/patents.